

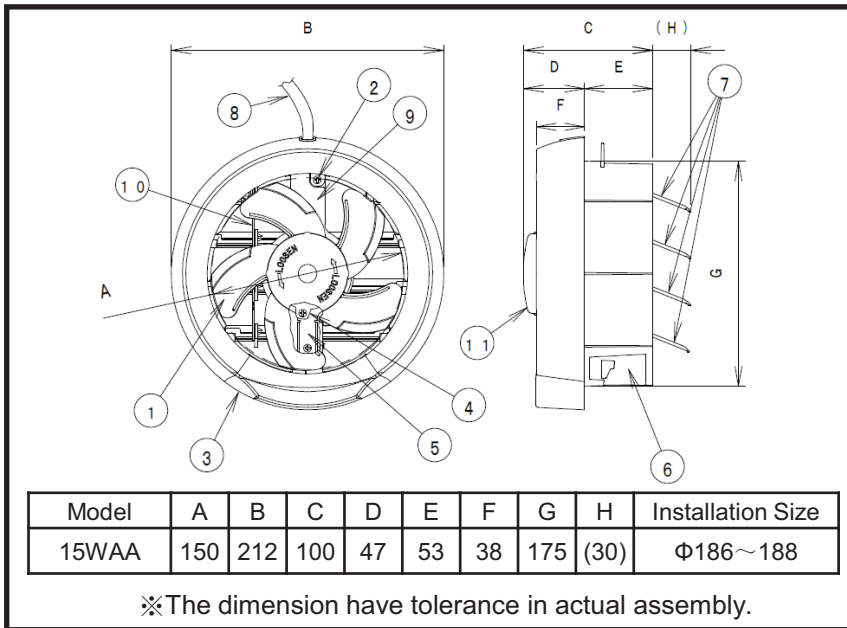



Specification Data Sheet

Unit: mm



| No. | Part Name | Material |
|-----|-----------------|------------|
| ① | Blade | Plastic |
| ② | Screw | Iron Steel |
| ③ | Orifice | Plastic |
| ④ | Motor | — |
| ⑤ | Motor Plate | Iron Steel |
| ⑥ | Frame | Plastic |
| ⑦ | Shutter | Plastic |
| ⑧ | Power Cord | — |
| ⑨ | Lead Wire Cover | Plastic |
| ⑩ | Lever | Plastic |
| ⑪ | Spinner | Plastic |

■ AMCA License



KDK Company, Division of PES and Panasonic Ecology Systems (Thailand) Co., Ltd. certify that the window mount series models shown herein are licensed to bear the AMCA seal. The ratings shown are based on the tests and procedures performed in accordance with AMCA Publication 211 and AMCA Publication 311 and comply with the requirements of the AMCA Certified Ratings Program.

■ Specification

| Model | Voltage | Frequency | CFM/SONE at static pressure(ps-inches of H ₂ O) | | | | RPM | Watts* | Watts** | |
|-------|---------|-----------|--|-----|------|------|-----|--------|---------|------|
| | | | inches of H ₂ O | 0 | 0.02 | 0.04 | | | | 0.06 |
| 15WAA | 220V | 60Hz | CFM | 124 | 109 | 91 | 79 | 2021 | 19.6 | 18 |
| | | | Sones | 3.6 | 4.5 | 4.1 | 4.0 | | | |
| | 240V | 50Hz | CFM | 124 | 109 | 93 | 78 | 2062 | 18.2 | 16 |
| | | | Sones | 3.5 | 4.5 | 4.1 | 3.8 | | | |

Performance certified is for installation type A: Free inlet , Free outlet.

Performance ratings include the effects of a shutter.

The speed (RPM) and Watts rating shown are at the static pressure of 0 inch of H₂O.

The sound ratings shown are loudness values in fan sones at 5 ft. (1.5m) in a hemispherical free field calculated per AMCA International Standard 301. Values shown are for installation type A: Free inlet hemispherical sone levels.

* the Watts rating is only for AMCA test method and it is at the static pressure of 0 inch of H₂O.

** the Watts rating is only for IEC test method and the AMCA Certified Ratings Seal does not apply to IEC test method watts.

| Product | | | Model | |
|------------------------------|------------|-------|------------------|---|
| Window Mount Ventilating Fan | | | 15WAA (AMCA) | |
| Make Date | 2015.01.06 | Scale | Drawing No. | — |
| Modification Date | | | Modification No. | |
| KDK Company, Division of PES | | | | |



Specification Data Sheet

Unit: mm

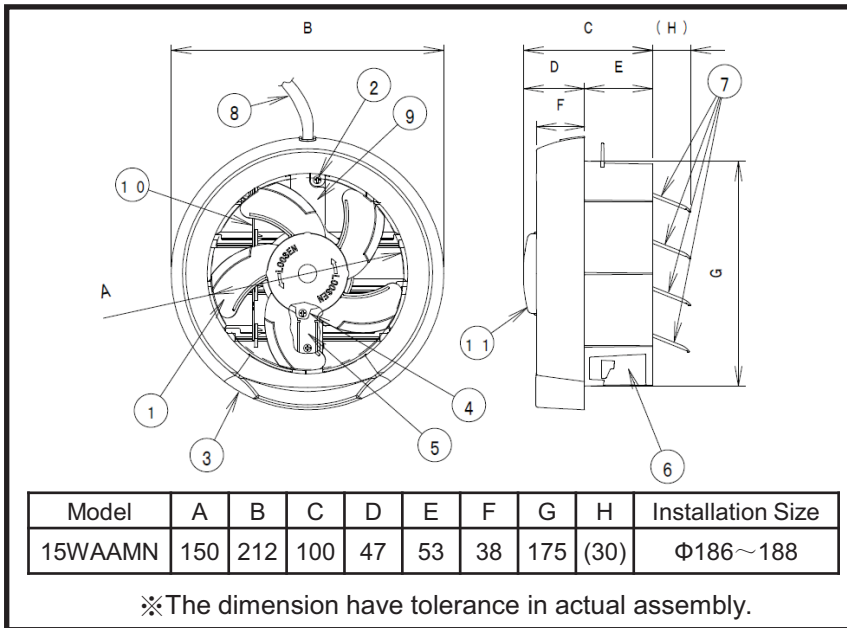

| No. | Part Name | Material |
|-----|-----------------|------------|
| ① | Blade | Plastic |
| ② | Screw | Iron Steel |
| ③ | Orifice | Plastic |
| ④ | Motor | — |
| ⑤ | Motor Plate | Iron Steel |
| ⑥ | Frame | Plastic |
| ⑦ | Shutter | Plastic |
| ⑧ | Power Cord | — |
| ⑨ | Lead Wire Cover | Plastic |
| ⑩ | Lever | Plastic |
| ⑪ | Spinner | Plastic |

AMCA License

KDK Company, Division of PES and Panasonic Ecology Systems (Thailand) Co., Ltd. certify that the window mount series models shown herein are licensed to bear the AMCA seal. The ratings shown are based on the tests and procedures performed in accordance with AMCA Publication 211 and AMCA Publication 311 and comply with the requirements of the AMCA Certified Ratings Program.

Specification

| Model | Voltage | Frequency | CFM/SONE at static pressure(ps-inches of H ₂ O) | | | | RPM | Watts* | Watts** |
|---------|---------|-----------|--|-----|------|------|------|--------|---------|
| | | | inches of H ₂ O | 0 | 0.02 | 0.04 | | | |
| 15WAAMN | 240V | 50Hz | CFM | 124 | 109 | 93 | 2062 | 18.2 | 16 |
| | | | Sones | 3.5 | 4.5 | 4.1 | | | |

Performance certified is for installation type A: Free inlet , Free outlet.

Performance ratings include the effects of a shutter.

The speed (RPM) and Watts rating shown are at the static pressure of 0 inch of H₂O.

The sound ratings shown are loudness values in fan sones at 5 ft. (1.5m) in a hemispherical free field calculated per AMCA International Standard 301. Values shown are for installation type A: Free inlet hemispherical sone levels.

* the Watts rating is only for AMCA test method and it is at the static pressure of 0 inch of H₂O.

** the Watts rating is only for IEC test method and the AMCA Certified Ratings Seal does not apply to IEC test method watts.

| | | | | |
|------------------------------|------------|-------|------------------|---|
| Product | | | Model | |
| Window Mount Ventilating Fan | | | 15WAAMN (AMCA) | |
| Make Date | 2015.01.06 | Scale | Drawing No. | — |
| Modification Date | | | Modification No. | |
| KDK Company, Division of PES | | | | |